



# Shakmat Ballista Blast

- 12HP Eurorack module
- Built & designed in E.U.

<b>1. Introduction</b> .....	<b>4</b>
<b>2. Specifications</b> .....	<b>4</b>
<b>3. Basics</b> .....	<b>5</b>
3.1 Main parameters controls.....	5
3.2 Menu screen and navigation.....	5
3.3 Synthesis menus.....	5
3.4 Memory.....	5
3.5 Trigger.....	6
3.6 Randomizer & Velocity.....	6
3.7 Integrated envelope.....	6
3.8 Micro SD Card reader.....	6
<b>4. Architecture</b> .....	<b>7</b>
<b>5. Oscillator</b> .....	<b>7</b>
5.1. Classic.....	7
5.1.1 Sub.....	8
5.1.2 Dual.....	8
5.1.3 Unisson.....	8
5.1.4 Sync.....	8
5.1.5 Width.....	8
5.1.6 Noise.....	9
5.1.7 Chords.....	9
5.2. Wavetables.....	9
5.2.1. Basic.....	9
5.2.2. Digital.....	9
5.2.3. Chiptune.....	10
5.2.4. Formant.....	10
5.2.5. Harmonics.....	10
5.2.6. Instruments.....	10
5.2.7. Vocals.....	11
5.3. FM algorithms.....	11
5.3.1. Fold.....	11
5.3.2. Bronze.....	11
5.3.3. Servo.....	11
5.3.4. Ferro.....	12
5.3.5. Additive.....	12
5.3.6. Flux.....	12
5.3.7. Chords.....	12
5.4. Tuning.....	12
5.5. FM/AM input.....	13
<b>6. Analog</b> .....	<b>13</b>
6.1. Filter type.....	13
6.1.1 Two-pole low-pass.....	13
6.1.3. Two-pole high-pass.....	13

6.1.2. Two-pole band-pass.....	13
6.1.4. Four-pole low-pass.....	13
6.2. VCF tracking.....	13
6.3. VCA mode.....	13
6.4. Distortion amount.....	14
6.5. Distortion type.....	14
6.6. Level.....	14
<b>7. Modulation.....</b>	<b>14</b>
7.1. Envelope mode.....	14
7.1.1 AR.....	14
7.1.2. AD.....	14
7.1.3. ASR.....	14
7.1.4. LOOP.....	14
7.2. Envelope shape.....	15
7.2.1 Linear.....	15
7.2.2. Exponential.....	15
<b>8. Modulation destinations.....</b>	<b>15</b>
<b>9. Randomizer.....</b>	<b>16</b>
<b>10. Velocity.....</b>	<b>17</b>
<b>11. Memory.....</b>	<b>17</b>
<b>12. Select Bus.....</b>	<b>18</b>
<b>13. Presets management.....</b>	<b>18</b>
<b>14. SD Card.....</b>	<b>19</b>
<b>15. User wavetables.....</b>	<b>19</b>
<b>16. Global Options.....</b>	<b>20</b>
16.1. Pot mode.....	20
16.2. Catch Display.....	20
16.3. Select Bus.....	20
16.4. Screen saver.....	20
16.5. Wavetable.....	21
16.6. Expander 1.....	21
16.7. Expander 2.....	21
16.8. Envelope Depth.....	21
16.9. Expander 1 Depth.....	21
16.10. Expander 2 Depth.....	21
<b>17. Expanders.....</b>	<b>22</b>
<b>18. Factory reset.....</b>	<b>22</b>
<b>19. Firmware upgrade.....</b>	<b>22</b>

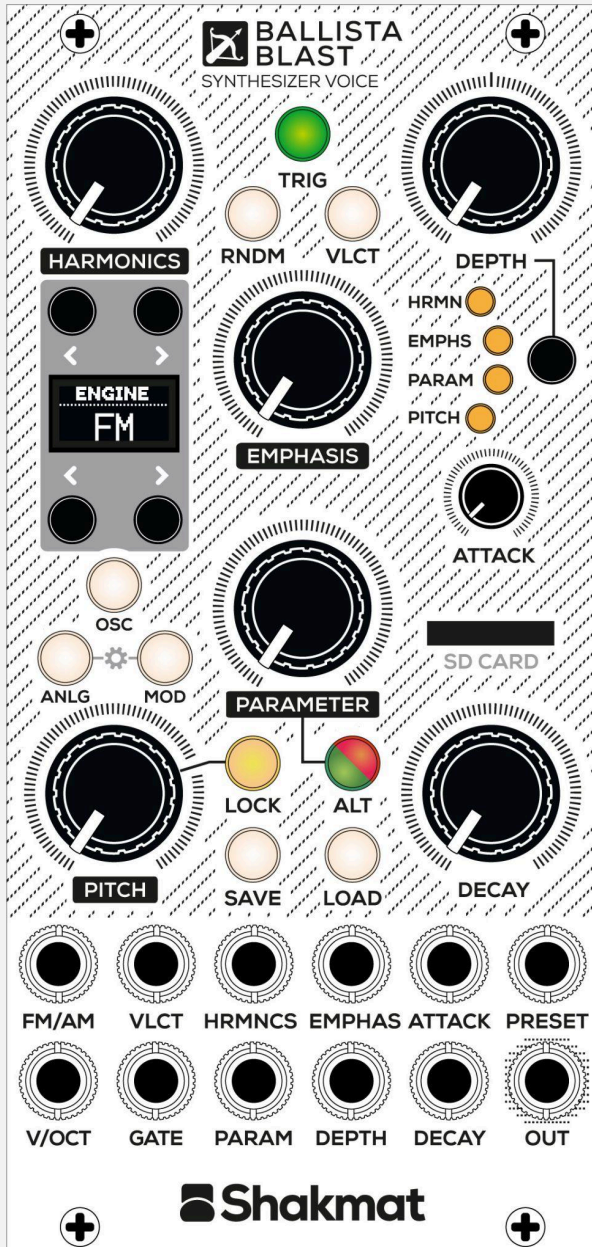

## 1. Introduction

The Ballista Blast is a compact hybrid synthesizer voice built to hit hard, move fast, and cover a serious amount of ground in just 12hp. It blends digital sound engines with a proper analog processing chain, so you can go from squelchy basslines to glassy textures, from smooth harmonic tones to wild, chaotic mayhem, without being stuck with a single ammunition type.

To keep things alive, the Ballista Blast includes a built-in envelope, an assignable random source, and a velocity input, all routable to nearly any parameter, so even the simplest patch can feel animated and performance-ready.

Because good shots deserve a save button, Ballista Blast stores 256 presets, with Select B1us support for quick recall in a system built for action.

## 2. Specifications

<b>Size</b> 12 HP	<b>Gate input</b> 0 to 5v
<b>Depth</b> 29 mm	<b>CV inputs</b> -5v to +5v
<b>Current draw</b> 135 mA @ +12v 45 mA @ -12v	<b>Velocity input</b> 0 to 5v
<b>VCO range</b> 13 Hz to 10 kHz	<b>V/Oct input</b> -3v to +7v
<b>VCO output</b> 16 bits 48 kHz	

## 3. Basics

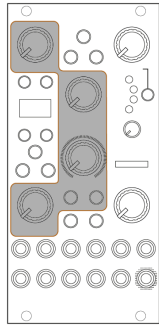

### 3.1 Main parameters controls

These four potentiometers control the main parameters of the synthesis engines : **HARMONICS**, **EMPHASIS**, **PARAMETER** & **PITCH**.

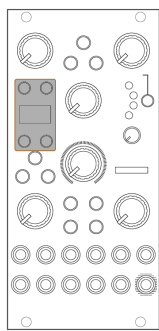

### 3.2 Menu screen and navigation

The menu screen is divided in two parts: the page title on top and the selected setting on the bottom. To browse through the pages, use the left and right buttons above the screen. To edit the setting, use the left and right buttons under the screen.

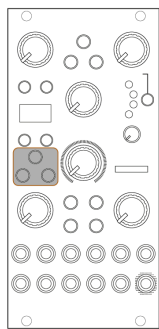

### 3.3 Synthesis menus

These three buttons open the main synthesis menus. The **OSC** menu allows you to select the synth engine and other parameters of the VCO. The **ANLG** menu sets several parameters regarding the VCFs, distortion and VCAs. The **MOD** menu handles the parameters of the modulation source(s), from the integrated envelope or connected expanders.

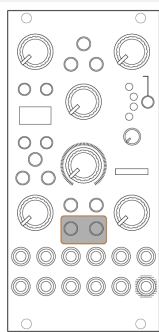

### 3.4 Memory

With the help of the menu screen and navigation, the **SAVE** and **LOAD** buttons allow you to recall and save up to 256 internal presets organised in 16 banks of 16 patterns.

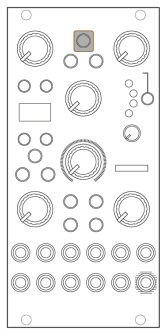

### 3.5 Trigger

Allows you to manually trigger sound and shows the activity of the VCA.

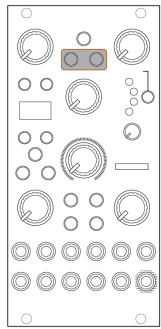

### 3.6 Randomizer & Velocity

Those two buttons open the randomizer and velocity assignment menu.

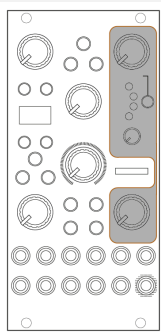

### 3.7 Integrated envelope

This part contains the onboard envelope parameters (attack, decay/release) and destination controls. Scroll the envelope destinations thanks to the destination button and LEDs while using the depth potentiometer to set the envelope depth on any of the main parameters.

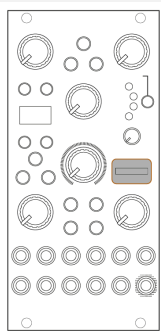

### 3.8 Micro SD Card reader

The micro SD card slot is used for firmware upgrade, importing wavetables and preset management. The Ballista Blast does not rely on the SD Card for functioning.

## 4. Architecture

The Ballista Blast has a mixed hybrid architecture with a digital core and an analog process chain. The digital core is providing VCO, modulations and control over the analog chain which includes several filters, a VCA/LPG and a distortion.

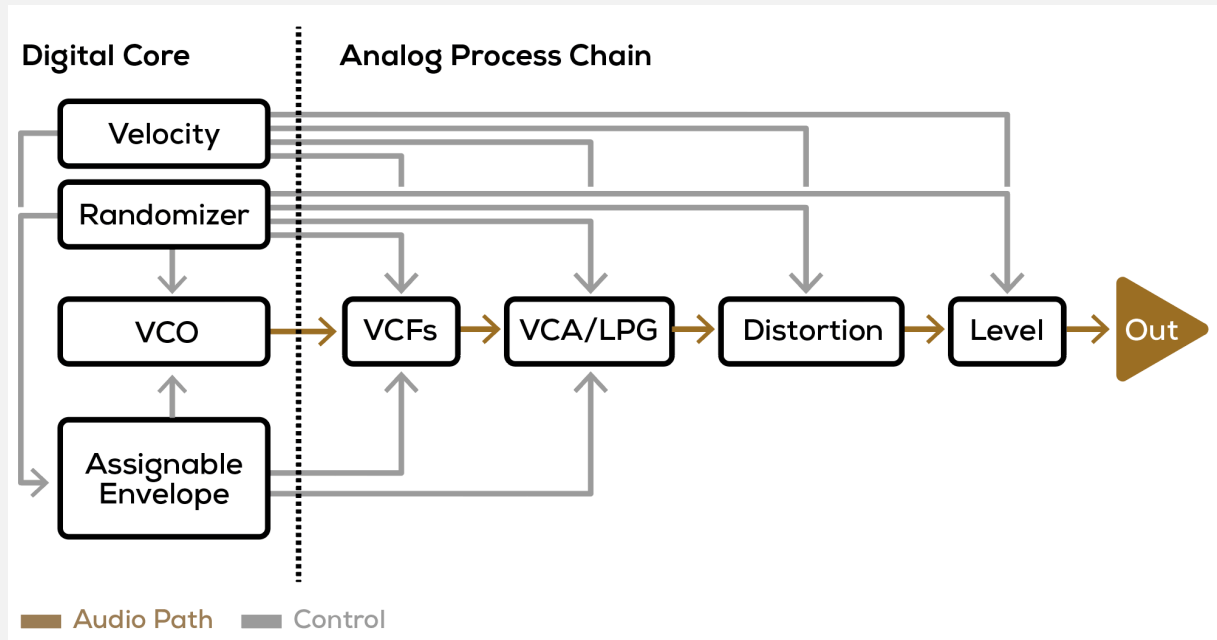

Each element of this architecture can be edited in the three main menus or in the velocity and randomizer menus. The three main menus are accessed thanks to the **OSC**, **ANLG** and **MOD** buttons. Velocity and randomizer are accessed thanks to the **VLCT** and **RNDM** buttons.

Each menu includes several pages which can be scrolled thanks to the < and > on top of the screen. Each page value can be edited thanks to the < and > buttons on the bottom of the screen.

## 5. Oscillator

The behaviour of the oscillator is defined by the selected engine which sets the type of synthesis used and also has an influence on the analog chain. The engine is selected from the first page of the oscillator (OSC) menu. There are 3 different engine types: Classic, Wavetables and FM.

### 5.1. Classic

The classic (*CLSSC*) engine is all about classic subtractive synthesis and offers seven different modes to combine saws or squares. Use the second page of the OSC menu to set a synthesis mode. Each mode includes an editable parameter, thanks to the **PARAMETER** potentiometer and **PARAM** CV input.

Activate the **ALT** button to select square waves instead of the default saw waves, an icon next to the synthesis mode shows the selection (the following screen captures shows the default saw waves configuration).

The Classic engine is a fully analog signal chain made of a filter, a distortion stage, and a VCA. **HARMONICS** sets the filter cut-off frequency and **EMPHASIS** sets the filter resonance.

For more details on these circuits and their behavior, refer to the Analog section of this manual.

#### 5.1.1 Sub



The Sub mode mixes the VCO waveform with a sub-octave. **PARAM** crossfades between the original waveform and its sub-octave.

#### 5.1.2 Dual



The Dual mode mixes two identical waveforms with different tuning. **PARAM** determines the relative tuning of the second waveform from -1 to +1 octave.

#### 5.1.3 Unisson



The Unisson produces supersaw and supersquares. **PARAM** is the amount of detune.

#### 5.1.4 Sync



The Sync mode syncs one VCO (slave) to a second VCO (master). **PARAM** defines the tuning of the slave VCO.

#### 5.1.5 Width



The Width mode produces variable width and waveforms. **PARAM** defines the width.

#### 5.1.6 Noise



The Noise mode mixes the VCO waveform with a white noise. **PARAM** crossfades between the waveform and the noise.

#### 5.1.7 Chords



The Chord mode produces 4 voices chords. **PARAM** sets the harmonic structure of the 4 voices from a predefined set of chords.

## 5.2. Wavetables

The wavetable (*WVTBL*) engine turns the VCO into a wavetable VCO, with 32 tables of 8 waveforms. When the wavetable engine is selected, the second page of the *OSC* menu allows you to choose the wavetable to be used. The wavetable engine uses the same analog chain as the classic engine which means that the **HARMONICS** parameter sets the filter cut-off frequency and **EMPHASIS** sets the filter resonance.

The **PARAMETER** potentiometer and **PARAM** CV input morph the eight waveforms of the selected table. The **ALT** button enables an ensemble effect, which provides a unison/chorus feeling to the sound.

The Ballista Blast comes with 32 banks of factory wavetables, but custom wavetables can be imported via the SD card. Refer to the User Wavetables chapter of this manual to learn how to import your custom wavetables. Here's the list of the factory wavetable banks:

### 5.2.1. Basic



A set of morphable classic analog waveforms

### 5.2.2. Digital



From *DIGI1* to *DIGI11*, are wavetables with complex and rich waveforms made by heavy digital processes.

### 5.2.3. Chiptune



From *CHIP1* to *CHIP4*, is a set of square-like, 1 bit and chiptune waveforms processed by lo-fi digital treatments.

### 5.2.4. Formant



From *FORM1* to *FORM4*, are four synthetic formants waveforms.

### 5.2.5. Harmonics

TABLE  
.....  
**HARM1**

From *HARM1* to *HARM4*, four additive synthesis wavetables with different harmonic feels.

### 5.2.6. Instruments

TABLE  
.....  
**CELLO**

A set of six tables made of waveforms taken from recordings of acoustic instruments: cello, pluck, Rhode, guitar, saxophone and trombone.

TABLE  
.....  
**GUITAR**

TABLE  
.....  
**PLUCK**

TABLE  
.....  
**RHODE**

TABLE  
.....  
**SAX**

TABLE  
.....  
**TROMB**

### 5.2.7. Vocals

TABLE  
.....  
**VOC1**

Two tables made of vocal recordings: *VOC1* and *VOC2*.

## 5.3. FM algorithms

The FM engine provides several FM models based on different algorithms including multiple operators. Those algorithms can be selected thanks to the second page of the OSC menu. Unlike the classic and wavetable engines, this one is not processed by filters and instead offers more control on the FM algorithms.

The **HARMONICS** parameter offers a macro control mainly linked to modulation depth. **EMPHASIS** sets different waveshaping, feedback and other modulation amounts. **PARAMETER** usually sets the relative pitch of the modulators.

The **ALT** button toggles between the free and ratio modes. In ratio mode (button is on), every modulator frequency is an integer ratio of the main operator, leading to more harmonic results. In free mode (button is off), the operator frequencies are “out of tune” leading to more inharmonic and chaotic sound materials. The seven available algorithms are as follows

### 5.3.1. Fold



Following the classic carrier-modulator approach, we added a wavefolder for your west-coast needs.

**HARMONICS** controls the FM depth.

**EMPHASIS** controls the wavefolder.

**PARAMETER** controls the tuning of the modulator.

### 5.3.2. Bronze



Combines three operators in series with modulators tuned to create soft metallic resonances.

**HARMONICS** controls the FM depth.

**EMPHASIS** adds an additional high pitched modulation.

**PARAMETER** controls the tuning of the modulators.

### 5.3.3. Servo



Three serial operators architecture with a totally different feeling, tailored for electronic basses, leads and plucks.

**HARMONICS** controls the FM depth.

**EMPHASIS** feedbacks the carrier and modulators.

**PARAMETER** controls the tuning of the modulator(s).

### 5.3.4. Ferro



Two carriers, each modulated by their own modulator, makes sounds from brutal metallic textures to rich bass.

**HARMONICS** controls the FM depth.

**EMPHASIS** is a macro of several waveshapers.

**PARAMETER** controls the tuning of the modulators.

### 5.3.5. Additive



Four oscillators in parallel for additive fun.

**HARMONICS** is the amount of harmonics in the waveform.

**EMPHASIS** adds high-pitched modulation for brightness.

**PARAMETER** is the tuning of the waveform's harmonics.

### 5.3.6. Flux



A simple two-operator architecture with a noise modulator.

**HARMONICS** controls the FM depth.

**EMPHASIS** sets the noise modulation amount.

**PARAMETER** controls the tuning of the modulator.

### 5.3.7. Chords



A FM chord generator with a two modulator architecture suited for dreamy pads and digital pianos.

**HARMONICS** controls the FM depth of the 1<sup>st</sup> modulator.

**EMPHASIS** is FM depth of the 2<sup>nd</sup> higher ratio modulator.

**PARAMETER** sets the chord.

## 5.4. Tuning

The **PITCH** potentiometer sets the oscillator frequency over a 3 octaves range. Pressing the **LOCK** button will lock the current **PITCH** set by the potentiometer, transforming it into an octave switcher able to shift the pitch one octave up or down.

When disabling the pitch lock, you'll need to turn the **PITCH** potentiometer past its previous position to reactivate its continuous pitch control. The Lock button will blink until the Pitch potentiometer passes its previous position.

The VCO can also be transposed thanks to the **OCTAVE** page of the **OSC** menu, from -3 to +3 octaves. Tuning of the VCO is controlled by the **V/OCT** input.

## 5.5. FM/AM input

The Ballista Blast features an **FM/AM** input. The fourth page of the OSC menu allows you to select its destination: *FM* (linear FM) or *AM*.

## 6. Analog

The Analog menu features several pages that control multiple parameters dependent on the selected engine. To access the Analog menu, press the **ANLG** button.

### 6.1. Filter type

#### 6.1.1 Two-pole low-pass

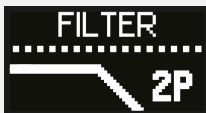

Ranging from soft and clean to nasty harmonic scanning, all the way into self-oscillation.

#### 6.1.3 Two-pole high-pass



The high-pass version of the two-pole low-pass filter.

#### 6.1.2 Two-pole band-pass



A Liquid and resonant band-pass filter.

#### 6.1.4 Four-pole low-pass



Steeper low-pass filter with an acid-flavoured resonance character.

### 6.2. VCF tracking

This menu page sets the VCF pitch tracking amount in increments of 10%, from no tracking (0%) to full tracking (100%), where the filter cut-off frequency follows the pitch of the VCO. Note that this menu page is not available for the FM engine.

### 6.3. VCA mode

This page sets how the VCA is driven, either by the envelope (*ENVLP*), the *GATE* (VCA opens while the **GATE** input is held high) or in *DRONE* mode which means that the VCA is always open.

### 6.4. Distortion amount

This page lets you select the distortion amount on a scale from *OFF* to 5.

## 6.5. Distortion type

Two distortion types are available: *I* & *II*. The first type is a classic and versatile soft-clipping distortion, ranging from subtle drive to more aggressive saturation. The type 2 is an asymmetrical distortion that generates both odd and even harmonics, and works especially well with rich analog material.

## 6.6. Level

This menu page sets the output level of the module. From a total mute to a boost of 6dB. As 0dB is a signal amplitude of 5vpp (without resonance), line level can be achieved at -3dB.

# 7. Modulation

An envelope generator with dedicated **ATTACK** and **DECAY** controls occupies the right side of the Ballista Blast. This envelope drives the VCA, and can also be routed to modulate the harmonics, emphasis, parameter, and pitch, each with an independent depth setting.

The modulation menu defines the envelope mode and shape. When an expander is connected, the modulation menu also sets these parameters for the expander. To access the Modulation menu, press the **MOD** button.

## 7.1. Envelope mode

### 7.1.1 AR

ENV MODE  
.....  
**AR**

Triggered attack and release..

### 7.1.3. ASR

ENV MODE  
.....  
**ASR**

Gated attack, sustain and release.

### 7.1.2. AD

ENV MODE  
.....  
**AD**

Gated attack and decay

### 7.1.4. LOOP

ENV MODE  
.....  
**LOOP**

Loops the envelope.

## 7.2. Envelope shape

### 7.2.1 Linear



Decay/release response is set to linear.

### 7.2.2. Exponential



















Decay/release response is set to exponential.

## 8. Modulation destinations

To assign the integrated envelope to one or multiple destinations, use the destination button (next to the destination's LEDs). Pressing the button will cycle through the four available destinations: harmonics, emphasis, parameter and pitch.

The destination's LED will inform you if a destination is selected, if it's assigned or not, and if the position of the DEPTH potentiometer currently matches the selected destination or not.

<p>HRMN </p> <p>EMPHS </p> <p>PARAM </p> <p>PITCH </p>	<p><b>Selected</b></p> <p>When a destination is selected, the corresponding destination LED is on.</p>
<p>HRMN </p> <p>EMPHS </p> <p>PARAM </p> <p>PITCH </p>	<p><b>Selected but the DEPTH potentiometer position does not match the current depth value</b></p> <p>When cycling through the destinations, if the <b>DEPTH</b> potentiometer position is different from the stored depth value, the destination LED will blink until the value is caught by the potentiometer.</p>
<p>HRMN </p> <p>EMPHS </p> <p>PARAM </p> <p>PITCH </p>	<p><b>Not selected and inactive</b></p> <p>When a destination is not selected and inactive (the depth value is zero), the LED is off. In the example, emphasis is assigned and harmonics is not assigned and not selected.</p>
<p>HRMN </p> <p>EMPHS </p> <p>PARAM </p> <p>PITCH </p>	<p><b>Not selected but assigned</b></p> <p>When a destination is not selected but is active, the LED is dimmed. In the example, emphasis is selected and harmonics isn't, but is assigned.</p>



Holding the destination button for two seconds clears the depth for all the destinations. Note that the **DEPTH** potentiometer works as an attenuator by default but can be set to work as an attenuverter using the global options menu.

## 9. Randomizer

The Ballista Blast includes a random value generator, triggered by the **GATE** input. Press the **RNDM** button (button lights up) to activate the Randomizer. Use the screen and buttons to assign it to one or multiple parameters (Harmonics, Emphasis, Parameter, Pitch, Depth, Decay, Attack, Level, and Distortion). An independent amount of randomness can be set to each destination, from 0 to 9.



Holding the **RNDM** button for two seconds clears all the random values. Once a parameter is set for randomization, the **RNDM** button will stay lit, or dimmed if the randomizer menu is not currently displayed.

## 10. Velocity

Just like the randomizer, the velocity can be assigned to each parameter with independent amounts from 0 to 9. The **VLCT** CV input is sampled and held by the **GATE** input while controlling the velocity setting.

For harmonics, emphasis, parameters, pitch, depth, decay, attack, level, and distortion destinations, the value received at the **VLCT** input is distributed and scaled for each parameter individually.

When the velocity-to-random is set to *OFF*, the randomizer affects the velocity as described above in the Randomizer chapter. When velocity-to-random is set to any other value, the **VLCT** input scales the amount of randomness applied to each destination. Lower velocity-to-random settings apply only a subtle scaling effect, while higher settings increase the influence of the randomizer on the velocity. Thus, at 0V on the **VLCT** input, the random amounts are completely suppressed. And at 5V, the random values reach the full values defined in the randomizer pages.



Holding the **VLCT** button for two seconds clears all the velocity values. Once a parameter is set for randomization, the **VLCT** button will stay lit, or dimmed if the velocity menu is not currently displayed.

## 11. Memory

The Ballista Blast can store up to 256 presets, divided into 16 banks of 16 presets. Each preset can be recalled manually, via the **PRESET** CV input, or Select Bus.

To save or load a preset, press the corresponding **SAVE** or **LOAD** button. Select a bank using the buttons above the screen and select a preset number using the buttons below the screen. Press **SAVE** or **LOAD** again to confirm.

A preset can be pre-listened before loading. To do so keep the **LOAD** button pressed while browsing through slots.

The load menu offers two more options : *INIT* which creates a basic preset free of any envelope assignment and *RNDM* which generates a random preset.

The bipolar **PRESET** CV input allows you to select a preset from the current bank. When a preset is selected from that CV input, the load menu screen is blinking.

## 12. Select Bus

The Select Bus protocol enables digital communication between modules through the ribbon cable used for power (at the back of the module). Communication occurs via pins 13 & 14 of the power connector, making it feasible only for modules employing large power cables (16 pins to 16 pins).

To enable Select Bus communication, a module needs to be set as a transmitter (master) and one or several modules must be set as receivers (slave). The Ballista Blast handles the Select Bus protocol as a receiver allowing the presets to be loaded and saved using a select bus transmitter module such as the Harlequin's Context. All the modules involved in the communication need to be connected to the same bus board.

The Select Bus protocol works with 16 scenes inside a bank. Messages addressing scenes higher than 16 will be ignored.

## 13. Preset management

The preset management menu allows you to import and export presets, per bank or as a whole, from and to a micro SD card. To do so, the SD card must be formatted as suggested in the following chapter. You can access the preset management menu by turning the Ballista Blast on while pressing the **SAVE** or **LOAD** buttons.

When importing presets, if there are more than 16 files named BB\_Presets\_Bank\_XX.txt in the folder, the module will import the first file in the alphabetical order. If there are less than 16 valid files in the folder, the module will not import anything.



The Ballista Blast comes with several banks of factory presets. Additional preset banks are available for import on [shakmat.com](http://shakmat.com).

## 14. SD Card

A micro SD card can be used to manage the presets, the user wavetables and to update the firmware of the Ballista Blast. The file structure of the SD card has to be as follows :

### SD Card file structure

---

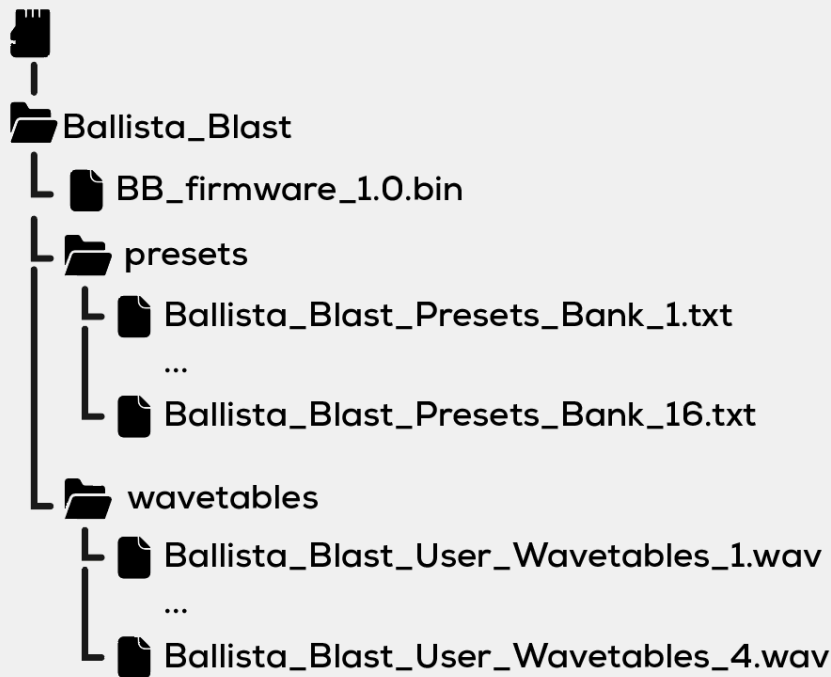

A zip file containing the right folder structure and files can be downloaded on our website at [www.shakmat.com/support](http://www.shakmat.com/support)

## 15. User wavetables

You can import your own wavetables to the Ballista Blast in wavedit format. 4 files of 64 wavetables are to be imported. Those 4 files will each be split into 8 segments, giving you a total of 32 banks of 8 tables (labelled as *USER01* to *USER32*).

WaveEdit is a free and open-source program made by Synthesis Technology (RIP Paul T. Schreiber). It allows for the creation and edition of wavetables. The WaveEdit wavetable format is a 16 bit mono .wav file containing 64 waves of 256 samples each (3 KB).

The wavetables will be imported in alphabetical order. If more than 4 files are present in the directory, the module will only import the 4 first ones. If less than 4 files are in the directory, the module will not import any wavetable

To import user wavetables, place the file in the wavetable folder as described in the previous chapter. Turn off the Ballista Blast, insert the card and press **VLCT** while powering the module up.

The user wavetables will not overwrite the factory wavetables. Instead, you have to choose a set of wavetables you want to use. Refer to the Global options chapter to learn how to choose which wavetable set is used.

## 16. Global Options

To access the global options you have to press the **ANLG** and **MOD** buttons together. By doing so the three main menu pages buttons will light up sequentially, indicating that you've entered the global options menu.

### 16.1. Pot mode

When changing presets, it is unlikely that a potentiometer still reflects the position of the current setting. This menu page allows you to set the potentiometer recall mode to either *CATCH* or *JUMP*. In *CATCH* mode, a potentiometer needs to pass by its previously stored value in order to be active again. In *JUMP* mode, moving a potentiometer will immediately set the value.

### 16.2. Catch Display

When the potentiometer recall mode is set to catch, this page enables the display of an icon on the screen that helps you find the previously stored value. The display will show if the potentiometer needs to be turned clockwise or counter clockwise until the previously stored value is caught.

### 16.3. Select Bus

Enable or disable the reception of Select Bus messages

### 16.4. Screen saver

This page enables and sets the screen saver timer which turns off the screen when the controls are not used for a defined amount of time.

## 16.5. Wavetable

This page allows you to choose the type of wavetable used by the module, either factory (*FCTRY*) or *USER*. Check the import user wavetables section for more information on how to import your own wavetables.

## 16.6. Expander 1

This page enables or disables the first expander.

## 16.7. Expander 2

This page enables or disables the second expander.



Enabling an expander when none is actually connected to the Ballista Blast, leads to erratic behaviour. When an expander is connected but disabled, all its destination LEDs are blinking.

## 16.8. Envelope Depth

This page allows you to choose if the **DEPTH** potentiometer acts as an attenuator or an attenuverter.

## 16.9. Expander 1 Depth

This page allows you to choose the behavior of the **DEPTH** potentiometer of the first expander (either attenuator or attenuverter).

## 16.10. Expander 2 Depth

This page allows you to choose the behavior of the **DEPTH** potentiometer of the first expander (either attenuator or attenuverter).



When a preset is recalled, if the DEPTH potentiometer is set as an attenuator and if it had negative depth assignments (because the potentiometer was in attenuverter mode when the preset was created), the assignments are ignored.

## 17. Expander(s)

The Ballista Blast can be expanded with up to two Ballista Blast Expanders. Each expander adds a flexible, assignable modulation source that can act as an extra envelope, an LFO, a random generator, and more. Compared to using an external modulation module, the expander offers more assignment flexibility, and its settings are saved and recalled with the presets.

To install a Ballista Blast Expander, connect it to either of the two expander headers on the main module, then enable it in the options menu. For more information about the expander, please refer to the Ballista Blast Expander user manual.

## 18. Factory reset

To restore your Ballista Blast to the factory presets & settings and clear its memory, hold the **RNDM** button while powering up the module. The screen will ask you to confirm or cancel the procedure. Note that the factory reset procedure will also clear the user wavetables.

## 19. Firmware upgrade

To update the Ballista Blast download the latest firmware from [shakmat.com/support](http://shakmat.com/support). Turn off the module, take the SD card out and copy the .bin file to the Ballista Blast folder as described in the SD cards chapter. Insert the card back in the module and turn it on while maintaining the **TRIG** button pressed. The screen will guide you through the end of the procedure.

• [www.shakmat.com](http://www.shakmat.com)